

RELEASE

DATE:

COMPANY:

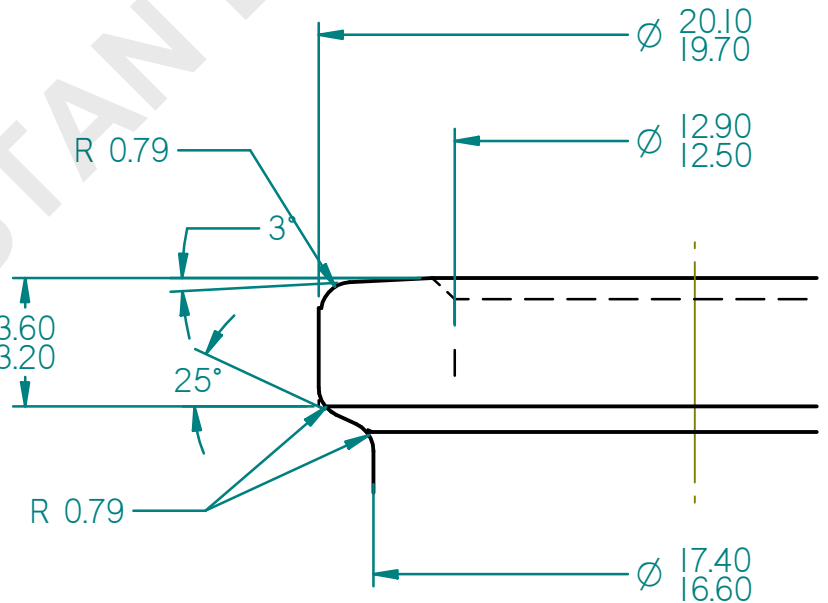
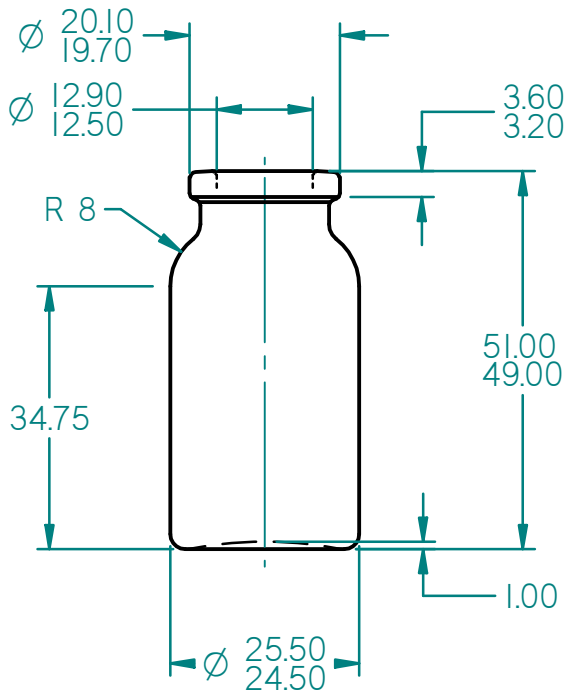

FINISH : 20 mm STD.

Protective note ISO 16016 observed

GENERAL TOLERANCES DIN 6129-1 (DIMENSIONS WITHOUT TOLERANCES ARE FOR REFERENCE ONLY)				FINISH: 20 mm STD.		O'FLOW CAPACITY: 13.50 - 15.00 ml		ARTICLE NO.: 5151010100			
				FINISH DWG: N.A.		WEIGHT: 18.5 g Approx.					
				FINISH MOLD NO: 910		TYPE OF GLASS: I COLOUR: FLINT					
				DATE	NAME		TITLE: 10 ml NATIONAL				
				DRAWN	12.10.2013 dipak						
				CHECKED	12.10.2013 H.B.P.						
				SCALE	1 : 1, 5 : 1						
				GERRESHEIMER NEUTRAL GLASS & ALLIED INDS. PVT. LTD. MUMBAI / KOSAMBA		MOLD NO.:	DRAWING NO.:		REVISION	SHEET	FORMAT
						033	B 1010		0	1 OF 1	A4
REV.	CHANGE	DATE	NAME	FILE: 10 ml National.dft							